

# NEW!

# Network Cabinet eLock

((( WIRELESS OR ETHERNET READY )))

## Access Control features:

- ◆ Easy installation on existing or new cabinets
- ◆ 3,000 user/supervisor codes
- ◆ Four modes of access: Keypad, Proximity card\* HID or iCLASS HID, Magstripe card\* (Track 2)  
*\*Use existing identification cards*
- ◆ Motor-driven latching mechanism provides the convenience of automatic relocking
- ◆ eLock is capable of operating two latches or doors
- ◆ Operates on 6 AA alkaline batteries or dedicated power supply
- ◆ Low battery indicator
- ◆ "Jump Start" 9-volt battery power port allows the user, with a valid credential, to access the CompX eLock® when the batteries are exhausted
- ◆ Programming can be done manually on user-friendly LCD blue backlit screen or through LockView® software
- ◆ Compatible with 12-volt electric door strikes to control access on interior doors
- ◆ Optional door switch provides instant notification of unauthorized entry or door ajar alerts



## Network features:

- ◆ Utilizes 802.11g wireless protocol or Ethernet communication on existing networks
- ◆ Enables two-way communication via common security encryption methods: WEP 64-key, WEP 128-key, WPA-PSK (TKIP), WPA2-PSK (AES) and other enterprise-class wireless security

Non-network units also available.  
Visit [compixelock.com](http://compixelock.com) for all eLock solutions.

**CompX**  
SECURITY PRODUCTS

Reorder #: F2644-029

Copyright 2011 © CompX Security Products / 847.752.2500 / [compix.com](http://compix.com) / 715 Center St., Grayslake, IL 60030  
Any companies and/or products referred to herein are marks or registered trademarks of their respective companies, owners and/or mark holders.

For more information, call **847.752.2500**

# LockView SOFTWARE

**LockView 4 is easy to use, with many programmable options, and allows access to any eLock from any computer on the network.**

## LockView® software features:

- ◆ Provides a comprehensive audit trail of the last 15,000 access attempts; including date, time and user name
- ◆ Escalating notification system sends alerts via email; optional Short Message Service provides Text Message, Voice Messaging or Fax alerts
- ◆ Complies with Joint Commission standards and is 21 CFR Part 11 compliant
- ◆ Compliance Dashboard provides at-a-glance status of all eLocks on the network
- ◆ LockView enables updates via the network to any eLock on the system. Updates can include:
  - User changes (Add / Delete / Modify Credentials)
  - eLock Changes (Add / Delete / Modify eLocks)
  - Access Rights changes

### Minimum System Requirements

MSSQL Server 2005 or MSSQL Server Express, 2GB memory, 2GB free space on hard disk, and Windows XP, VISTA, or 7. Other configurations are acceptable; please consult factory for detailed information.



Network cabinet eLock has three components:

**Controller**

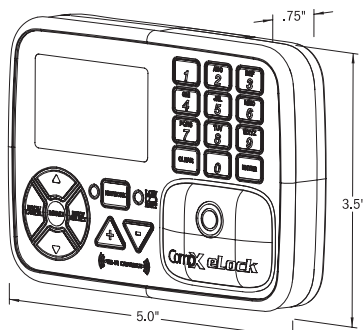

**Exterior mount**

**Motorized gear-driven latch**

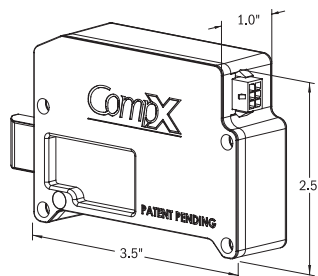

**Interior mount**

**Battery compartment**

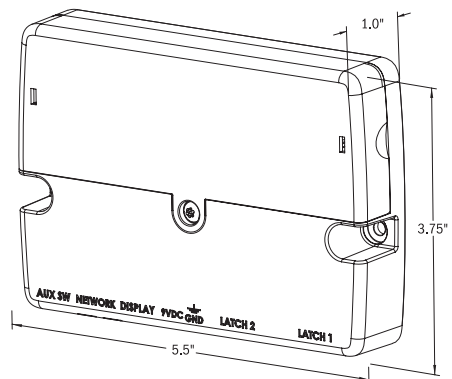

Reorder #: F2644-029

Copyright 2011 © CompX Security Products / 847.752.2500 / compx.com / 715 Center St., Grayslake, IL 60030  
Any companies and/or products referred to herein are marks or registered trademarks of their respective companies, owners and/or mark holders.

For more information, call **847.752.2500**